

SECTION 6. MAINTENANCE

All maintenance must be carried out by competent personnel and with the valve safely removed from situ, preferably on a suitable bench.

To aid maintenance, see the Parts Identification section of this manual.

6.1 Partial Strip Down

This section deals with the removal of the control ring/diaphragm assembly from the valve body.

1. With care fully open the valve.
2. With one hand supporting the valve body, use the other to gently pull the top bead of the diaphragm from the valve body. This is done by pulling at the thin wall of the diaphragm about 50mm away from the bead, in a direction perpendicular to the face of the valve top flange.

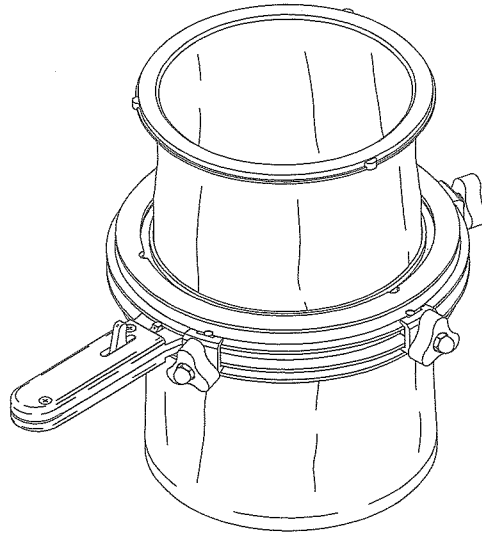

3. Repeat 6.1.2 for the bottom bead of the diaphragm.
4. Loosen the quick connect clamps, and unscrew until they reach the dome nut stop.

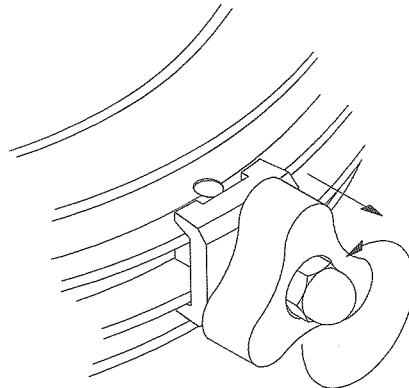

5. The two body halves can now be separated and the clamps removed. The control ring/diaphragm assembly can now be replaced or further stripped down.

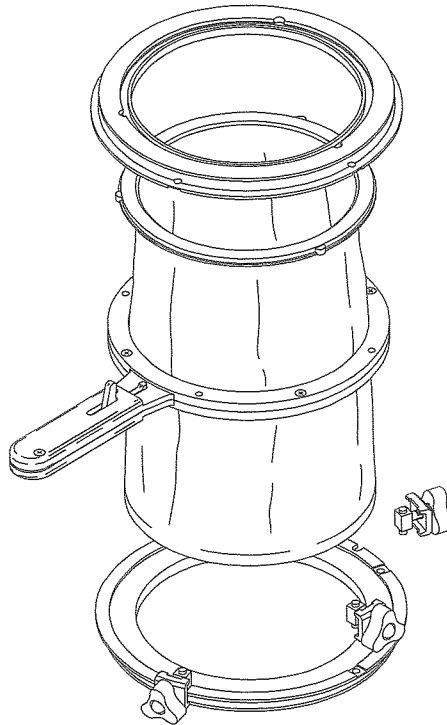

6.2 Full Strip Down

The full strip down of the valve includes removing the diaphragm from the control ring and full dis-assembly of the quick connect clamps.

There are two options available for the K-Valve control ring; all plastic and the stainless steel chassis design. The following simple operation is similar in both cases, with details of the design variation given in the parts identification section of this manual.

1. Remove the control ring/diaphragm, and quick connect clamp assemblies from the valve body as described in 6.1 above.
2. Using a 'Pozi-drive' size 2 screw driver, remove the screws from both sides of the control ring.
3. Remove the top half of the control ring, exposing the internal trigger, spring, serial number plate and diaphragm central bead.

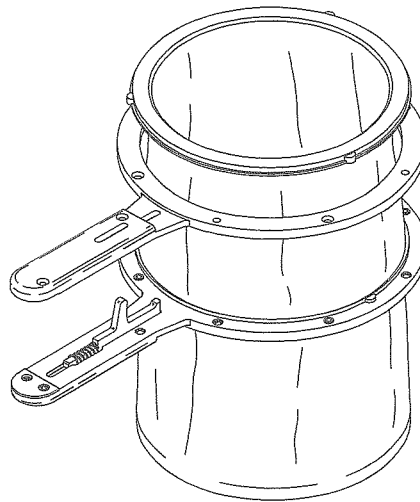

4. The remaining parts can carefully be removed from the diaphragm.

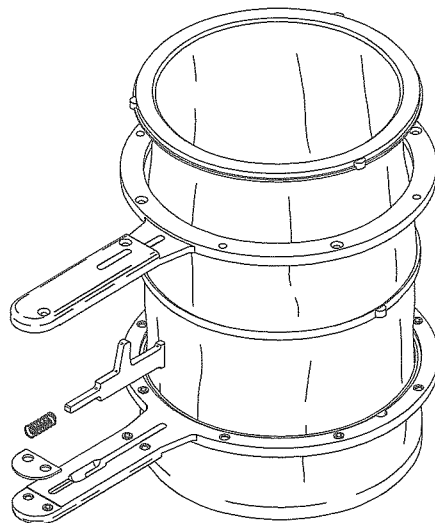

5. To dis-assemble the quick connect clamps, screw the hand knob down towards the tee end of the bolt, and using a 13mm A/F open ended spanner remove the, now fully exposed, dome nut from tee bar.

6. With the dome nut removed, the hand knob, spring washer and clamp segment can be removed from the tee bolt.

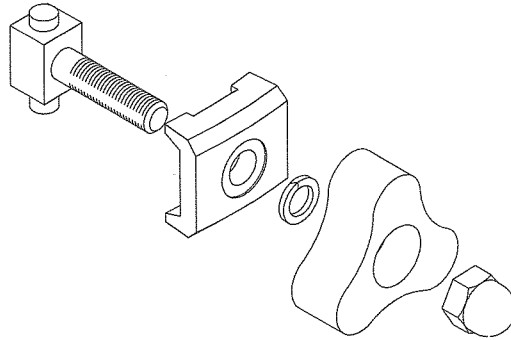

6.3 Fitting a Diaphragm to the Control Ring

1. Take the replacement or cleaned diaphragm and open it out into a tubular shape.
2. Take the bottom half of the control ring and gently push the bottom bead of the diaphragm through it from the grooved side of the ring.
3. The orientation of the diaphragm in the control ring is vital. When viewed from above, the control ring handle should point horizontally to the left, and the 'M' of MUCON PRODUCTS, moulded on the top bead of the diaphragm should be at 12 o'clock. In this position the anti-spin lugs on the centre bead of the diaphragm should line up with the corresponding recesses in the control ring groove.
4. Fit the central bead of the diaphragm into the control ring groove, ensuring it locates evenly around its circumference, and that both anti-spin lugs fit into their respective locations.
5. Slide the spring over the thin end of the trigger, and locate both in the control ring handle.
6. Fit the serial number plate into the recess at the end of the control ring lever. (Only all plastic types)

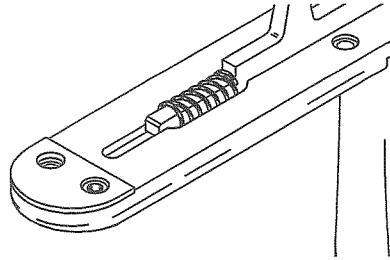

7. Gently push the top bead of the diaphragm through the top half of the control ring from the grooved side of the ring.
8. Slide the top half of the control ring down the diaphragm and locate on the top of the bottom half. This should enclose the trigger, allowing the operating section to protrude through the slot, it should also clamp the diaphragm centre bead and serial number plate in position.
9. Using a 'Pozi-drive' size 2 screw driver, fit all screws into both sides of the control ring. Note, the four longer screws are for use in the handle section of the control lever. Do NOT use power drivers, and only apply hand torque to the screws.

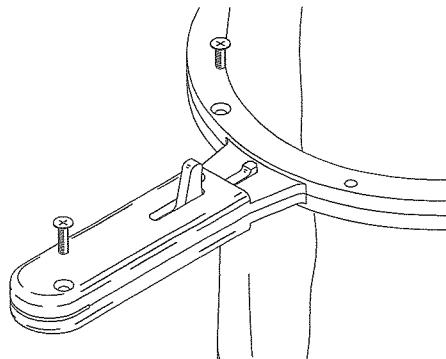

6.4 Fitting the Control Ring/Diaphragm Assembly to the Body

1. Keeping the control lever in your left hand, gently push the bottom bead of the diaphragm through the bottom half of the body. Rotate the bottom body until the closed position notch is on the opposite side of the valve to the trigger.
2. Locate the control ring in the recess on the bottom body. Ensuring that the trigger has cleared the outside edge.
3. If required re-assemble the quick connect clamps and secure the dome nut with a 13mm A/F spanner. Place the longer of the two round dowels on the tee bar into the hole in the body. Ensure the hand knobs are fully wound out towards the dome nut. Repeat this for all of the quick connect clamps.

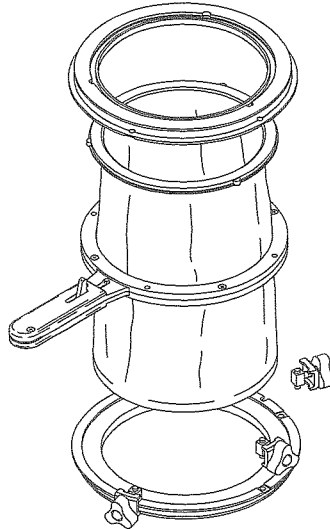

4. The clamps should locate in a small square recess to prevent them from rotating when operated.
5. Gently slide the top bead of the diaphragm through the top body half, from the underside, and locate the body onto the remaining dowels on the quick connect clamps. Note, care must be taken not to trap any of the loose, thin diaphragm material between the two body parts and the control ring. Gently spin the control ring, it should rotate freely. If not disassemble, inspect the diaphragm for damage, and start again.
6. Hand tighten all the knobs on the clamps, ensuring the clamping quadrant locates on the angled body rings, both top and bottom.
7. With the control lever still in the open position, take any one of the anti-spin lugs on the top bead of the diaphragm and locate it in the recess provided, directly below it. Repeat this for the other two anti-spin lugs.
8. To insert the rest of the top bead, start from a point midway between two of the anti-spin features, insert the 2mm square section of the bead deep into the outer edge of the groove in the body, apply pressure at 45° to the inner edge of the bead until it clicks into the groove. Work from this central position in each direction until this section of the bead is totally installed. Repeat this operation for the remaining two sections of the top ring.
9. Turn the valve over, keeping it in the fully open position.

10. The bottom bead of the diaphragm is of a different design to the top, helping to prevent incorrect installation. In order to install the bottom bead it is first necessary to rotate the bead through 180°, by rolling the bottom of the diaphragm outwards and downwards, towards the body.
11. The installation procedure is similar to that of the top ring, starting with the anti-spin lugs, and working from the centres between these features. However, the bead is simply pressed into the groove with direct pressure, perpendicular to the surface of the valve.
12. The valve should be opened and closed a few times to ensure correct operation, and that the diaphragm is fully installed correctly

NOTE:

If difficulty is encountered pressing either the top or bottom beads into position, dampen the beads slightly with water or another lubricant and allow to dry before operating the valve. If preferred a dusting of talc/chalk or even product may be used.

Kemutec
130 Wharton Road - Bristol, PA 19007
Tel: 215 788 8013 - Fax: 215 788 5113
Email: Sales@KemutecUSA.com
Web: www.Sales@KemutecUSA.com