

Cantilever Design Centrifugal Sifter

DS478TS 5/11



Kek Cantilever Design Centrifugal Sifter

Cantilever design Kek Centrifugal Sifter comes from a long line of proven sifting equipment. The easy clean and tool free design allows for maximum output and uptime. Its oversize hinged door provides quick access to the hygienically design sifting screens. The Kek Cantilever design Centrifugal Sifter is ideal for Food, Pharmaceutical, Powder Processing and Chemical Industries.

Cantilever Design Kek Centrifugal Sifter Features



- Hinged Oversize Door for Easy Cleaning and Operation
- Quiet Vibration Free Operation
- Fully Rotatable Screen for Inspection and Cleaning
- Bolted Flanges for Dust Tight Operation
- Tool Free Removal of Sifting Screen, Screen Retainer and Paddle/Blade Assembly
- Flexible Design Reduces Floor Space and Meets every Processing Requirements
- No Oversize End Bearing or Seals for Fewer Moving Parts to wear or replace
- Hygienic Design
- Screen Changes in Less Than 30 Seconds



Cantilever Design Centrifugal Sifter

Cantilever Design Centrifugal Sifter Principle of Operation

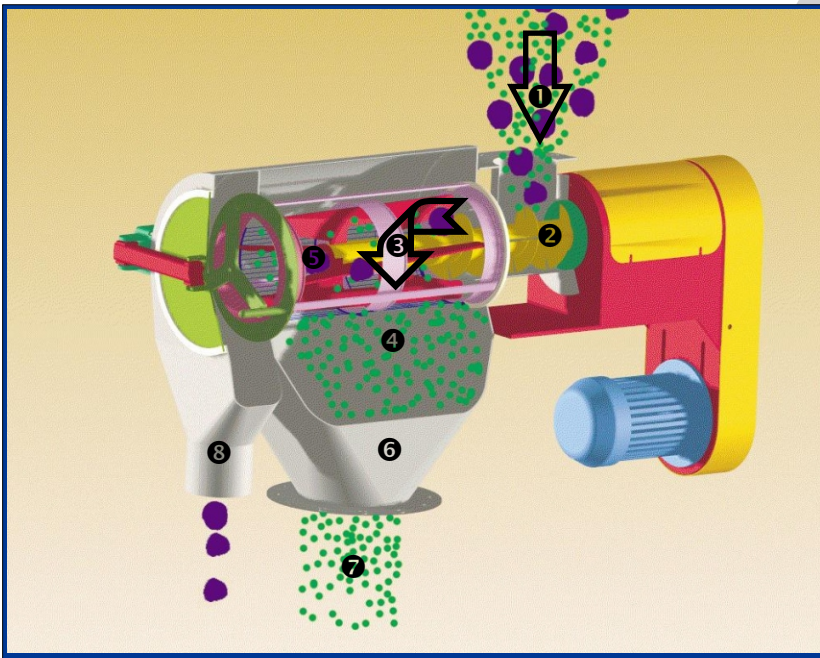

Material is fed into the sifter inlet ① and is accelerated by the auger ②. The auger moves the material into the cylindrical sifting chamber where it is picked up by the rotating paddle/blade assembly ③ and thrown centrifugally against the sieve screen ④. The blades ⑤ on the paddle assembly are set in a helical configuration to move the material along the entire length of the sieve screen at the optimum sieving rate for any particular application. The fine product ⑥ passes through the screen and is collected at the main sifter outlet ⑦. The oversized and/or tramp material is moved to the end of the sifting chamber and, after passing around the end baffle, is discharged through a separate smaller outlet ⑧.

Typical Applications

Kek Centrifugal Sifters are ideal for the following powders:

- Food /Dairy - powders, mixes, additives, granules, crumbs, spices and dehydrated products
- Pharmaceutical - powders and granules
- Plastics - powders, resins, and paints
- Chemical - powders, granules, additives, resins, dyes, pigments and metals
- Any application requiring highly efficient sifting, frequent cleaning and no cross-contamination between batches

Kek Centrifugal Sifters are ideal for the following applications:

- Scalping to remove oversize particles
- Policing to remove foreign particles and objects
- Size classification of powders
- De-lumping and de-agglomeration of powders
- Liquid Straining

Kemutec Technical Specification

Kek K300C Centrifugal Sifter with "Cantilever Shaft"

Drawing No. DS478

Body Type: One piece c/w fines outlet and integral oversize end. A hinged & interlocked Inspection Door fitted to right hand side of body. Ground bosses fitted at inlet & inlet for continuity.

Inlet/Outlet Connections: Flanged connections on the inlet and outlet - see drawing for details

Oversize End Connection: 'Triclover' type ferrule and safety grid - See drawing for details.

Oversize End Door: Fitted with a hinged & interlocked door

Motor Specification: 0.75 hp metric frame, 3 phase, (60 hz) motor non hazardous area

Sifter Shaft Speed: Via Belt Drive 1000 rpm. Shaft rotation - counter clockwise viewed from Oversize End

Shaft / Bearing Type: Cantilever Shaft supported at inlet end only by a pair of heavy duty sealed for life flanged ball bearing units fixed to drive support housing/bracket

Shaft Seal: At inlet end only. Twin nitrile rubber lip seals mounted in a bolted seal housing c/w air purge connection between seals. Air-purge is pre-piped from seal to a bulkhead fitting on the housing to accept 1/4" o/dia nylon tube.

Air/Gas Purge Requirement: The Air Purge facility requires compressed air/gas from a clean dry supply, regulated to 0 to 1 bar g (0 to 15 psi). Usage rate is approx 7 cuft/min at 0.5 bar g / 7.5 psi.

Gaskets: All gaskets are FDA approved white food quality rubber

Infeed Scroll Type: Standard AL type requires controlled feed of product. Rate-limiting Scrolls available as an option.

Shaft Paddle: 3 blade all welded with 4.5 degree forward pitch. Fitted with 'Intra-Baffle'.

Paddle Wiper/Brushes: 3-off adjustable bolted wiper blades fitted to paddle blades.

Sieve Basket Retainer & Oversize Baffle: A combined Sieve Basket Retainer with screw adjustable Baffle Plate to allow adjustment of material flow to oversize.

Sieve Mesh Area: 0.93 ft² = 0.086m²

Sieve Basket: To suit CE/1 Nylon or Woven Wire Mesh types as standard.

Sieve Meshes: Woven nylon or wire mesh as standard. Options of Wedge Wire and Perforated Plate are offered.

Safety Interlocks:

A. Fitted to side access door as standard: Allen Bradley plunger limit switch, IP65, 1 pair NO +1 pair NC contacts, M20 conduit thread entry.

B. Fitted to oversize end as standard: Allen Bradley plunger limit switch, IP65, 1 pair NO +1 pair NC contacts, M20 conduit thread entry.

Maximum Temperatures:

Nylon meshes	176° F	80° C
Silicone gasket	392° F	200° C
Nitrile shaft seals	176° F	80° C
PTFE shaft seals	392° F	200° C
Flanged bearing units	212° F	100° C

Operating Pressure: +/- 0.5 psi

Altitude: Maximum 1000 m above sea level (due to motor cooling). High Altitudes - O.A.

Optional Features (please request):

- Rate Limiting Infeed Scrolls in place of standard scroll.
- Stainless steel drive support and guard instead of painted carbon steel items.
- Left hand body inspection door instead of standard right hand version.
- PTFE shaft lip seals.
- Hazardous area drive motor and door interlocks.
- Zero or reverse pitch Paddle Assemblies.
- Oversize Collection Canisters
- Polyester / PFK / Anti-static polymer meshes.
- All welded one piece shaft / scroll /paddle assembly
- Mobile support stand

Alternative Machine Types:

- Cut-off Fines Outlet - See drawing DS489
- K650C Inline Vacuum
- See Drawing DS479



DO NOT SCALE DRAWING - IF IN DOUBT ASK

INLET & OUTLET CONNECTIONS MUST BE SUITABLY GUARDED TO PREVENT OPERATOR ACCESS. TO ROTATING/MOVING PARTS IN LINE WITH RELEVANT SAFETY REGULATIONS (SEE BS EN 294/BS5304:1986).

NOTE
SAFETY INTERLOCKS MUST BE WIRED INTO THE DRIVE MOTOR'S CONTROL CIRCUIT (BY CLIENT) TO PREVENT THE MOTOR RUNNING, SHOULD EITHER INTERLOCK BE ACTUATED BY OPENING OF THE INSPECTION DOOR OR OVERSIZE END

SCREEN AREA = 0.066m² (NYLON MESH)
0.077m² (WIRE MESH)
NET WEIGHT = 50 kg

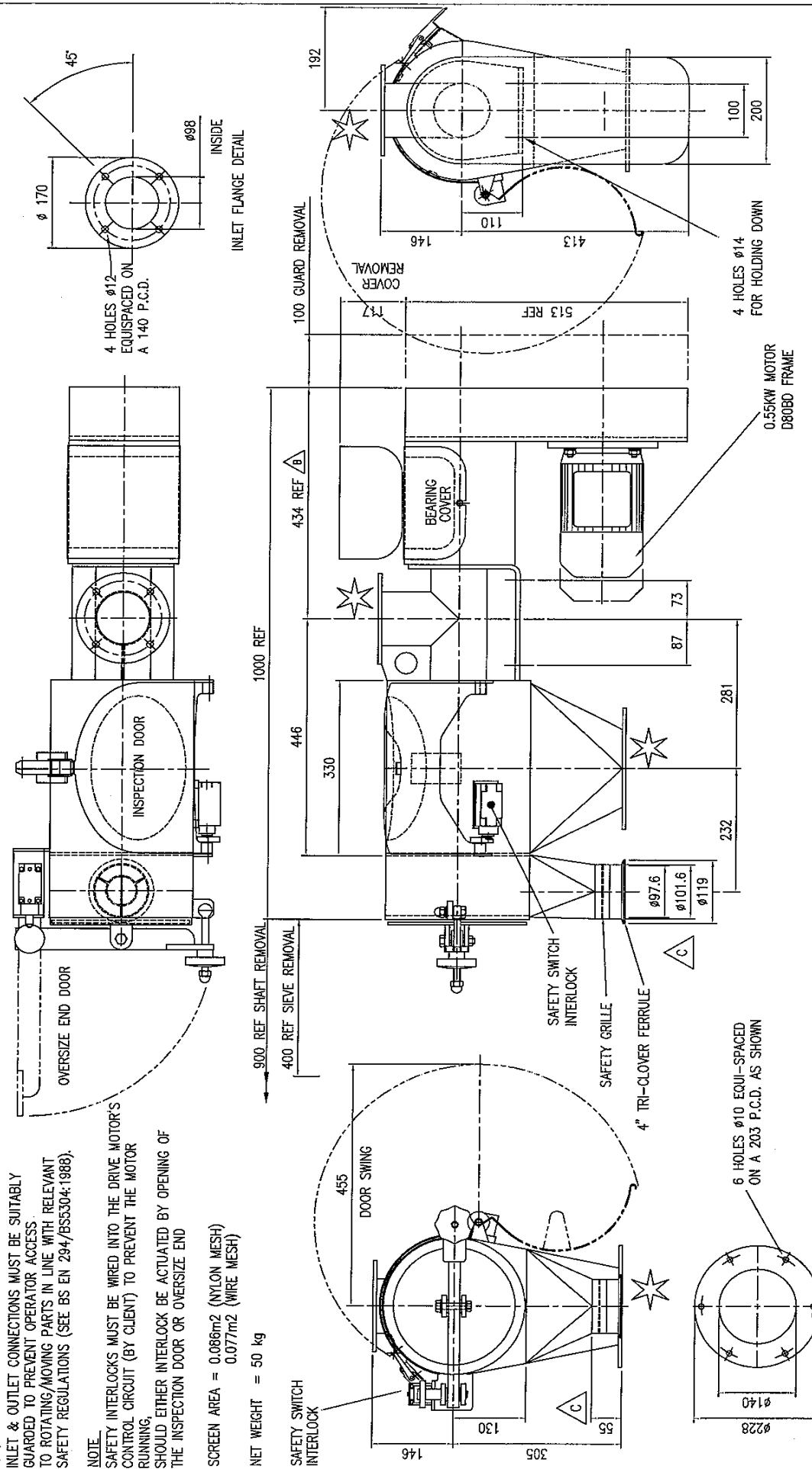

Kematec Powder Technologies Ltd
 Spelwood Way, Alcesterfield
 Tel: +44 (0)1825 412000
 Fax: +44(0)1825 412001
 Web: www.kematec.com
 Email: info@kematec.com

DRAWN BY: *J.P. 24/9/99*
 CHECKED BY:
 APPROVED BY:
 SCALE: 1:5
 DATE: 13/02/99

TITLE
 K300C SIFTER ARRANGEMENT
 C/W CANTILEVER SHAFT

DRAWING No
 A2 DS478

ISSUE C
 C

ISSUE B
 MINOR CHANGES. SEE DCN584 PB 7/5/99

ISSUE C
 USE NOW 4" TRICLOVER WAS 90 0/D PB 19/07/03

DRAWING SPECIFICATIONS		TOLERANCE SPECIFICATIONS		ALL DIMENSIONS IN MILLIMETRES	
UNLESS OTHERWISE STATED		UNLESS OTHERWISE STATED		THIRD ANGLE PROJECTION	
Screw threads to BS5343	50 Metric Coarse Pitch Series (Medium Fit)	ISO METAL DIMENSIONS	ISO UNFINISHED DIMENSIONS	For all material, weld and finish specifications refer to purchase/works order unless stated otherwise	
And must not be copied or shown to a third party without the written consent of this company.	Metric Symbols to BS2874 Part 2	0 to 300 ± 0.10	0 to 150 ± 0.08		
	Dimensional & Geometrical tolerances to BS2874	300 to 1000 ± 0.15	150 to 300 ± 0.12		
	Units & Fits to BS2000	1000 to 10000 ± 0.20	Over 100 ± 0.10		
	Remove all sharp edges and burrs				

WT 10/02